

WATERCO

water, the liquid of life

www.waterco.com

MICRON

COMMERCIAL FIBREGLASS FILTERS

Proven Strength and Durability



Setting new global benchmarks in durability, versatility, reliability and longevity, Waterco's Micron fibreglass filters are the preferred choice for commercial and industrial operations that demand superior water quality.

Micron Fibreglass Filters

Weighing two-thirds less than its steel counterpart - making it easier to ship and install - with a material that is resistant to both mechanical and chemical influences, Waterco's Micron commercial fibreglass filter range can be adapted to a wide range of applications including large public swimming pools, aquatic parks, hotel and resort pools, aquaculture, cooling towers, drinking water systems, food and beverage processing, industrial processes, water features, zoos, and aquariums.

Manufactured from the highest grade of non-corrosive materials, Micron fibreglass filters are ideal for harsh environments including seawater applications. Available in top mount, side mount and horizontal configurations, Waterco has the capability of adapting its fibreglass filters to meet customer specifications.



**Resort World
- Singapore**

**South Australia Country Water
Quality Improvement Program -
South Australia, Australia**

**Desalination plant
- Faw region in Basrah, Iraq**

**Mablethorpe Seal Sanctuary
- United Kingdom**

**Coal seam gas filtration -
Queensland, Australia**

**Glen Eira Sports & Aquatic
Centre - Victoria, Australia**



12 Micron MD6500 Commercial Fibreglass Filters and 11 Micron M5000 Commercial Fibreglass Filters purify over 15 million litres of water at Asia's premier destination resort, Universal Studios on Sentosa Island in Singapore. The Micron M5000 filters are used for the water theme park (9,900m³ volume of water), while the Micron MD6500 filters are installed to service three different attractions,

This was a multi-staged project to deliver high quality filtered drinking water to the state's rural and remote communities. Waterco was instrumental in this initiative, installing 8 Micron SMDD2200 Commercial Fibreglass Filters and 17 Micron SMDD2500 Commercial Fibreglass Filters filled with granular activated carbon to remove unwanted taste and odours during final filtration stages.

Like numerous Iraqi governorates, the Al Faw region in Basra experiences severe shortages of drinking and irrigation water. In order to supply potable water to its growing population, millions of dollars are being invested into sophisticated desalination and filtration technologies. Waterco was commissioned to supply 40 Micron SMD2000 Commercial Fibreglass Filters in four water desalination plants, which each has an output of 100m³/hr. The combined pre-filtration flow rate is approximately 1000 - 1100 m³/hr.

Micron Fibreglass Filters have shown themselves to be very effective in catering for sea animals such as seals and various other wildlife parks and zoos all over the world, which made them an obvious choice for the Mablethorpe Seal Sanctuary. Two Micron SMDD 1050 Fibreglass Filters were installed with glass media.

The Micron SMDD 1050 filter improves the filtration efficiency over standard high-rate filters by providing enhanced in-depth filtration, a superior lateral under drain design and increased dirt capacity.

Waterco Micron fibreglass filters were installed conjunction with an ion exchange filter media to remove sodium out of the incoming water whilst adding calcium and magnesium. The end result is recycled water that is ideal for soil and plant health.

Glen Eira Sports and Aquatic Centre (GESA) features five separate pools, two water slides, and a fully equipped aquatic wellness area. The aquatic centre has been equipped with Waterco's Micron Air Scour Horizontal filtration system, which has resulted in a saving of between 25 and 35 per cent of the backwash water.

Seamless one-piece vessel

Waterco's Micron Commercial Fibreglass Filters are made from continuous strands of high quality fibreglass filament wound under controlled tension to create a seamless, impervious vessel. This produces a filter that is free from welds or seams, or special tank linings that typically corrode or electrolyse. Waterco's revolutionary winding technology further strengthens the fibreglass structure so it can withstand a working pressure of up to 1,000 kPa (150psi).



Strict quality control

Waterco's quality control procedures ensure that the structural requisites of the product are achieved at every stage of production. This results in 100% compliance of the end product with the specifications.



Proprietary construction

The design and manufacturing process of the fibreglass vessel, utilising the latest filament winding machines, incorporation of non-metallic fittings plus reinforced manhole openings with proprietary methods, is unique to Waterco.

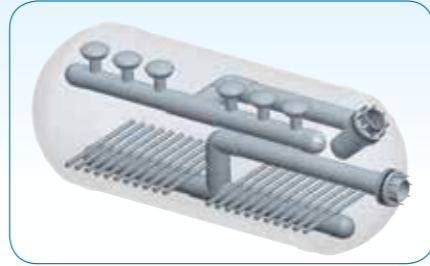

High corrosion resistance

Fibreglass vessels are rapidly replacing steel tanks in numerous applications. Firstly, they have a superior mechanical and chemical resistance to steel. Also, they do not rust or corrode and are able to withstand damage from many types of water treatment chemicals. Furthermore, these vessels are ideal for seawater applications, such as pre-filtration for desalination systems.



Rusky Island Desalination Plant - Vladivostok, Russia

When Rusky Island was chosen as the site for the 2012 Asia-Pacific Economic Cooperation Leaders' Week (APEC), the Russian Central Government decided to construct a large-scale desalination plant capable of purifying over 2.6 million gallons of seawater per day. Integral to this was a 10,000 m³/d seawater reverse-osmosis (SWRO) system to support the drinking and processing needs of local residents

and the new Far Eastern Federal University, location of the APEC Summit.

Given the harsh environment and the need for hard-wearing, extreme-weather components, Waterco provided 12 x 7-bar-rated Micron MD10,000 horizontal fibreglass filters for the project. Designed with no metal-to-water contact, they do not suffer from corrosion like steel or stainless steel vessels.



Low maintenance

Once installed there are virtually no maintenance or repairs required. Steel vessels require the anti-corrosive coating to be maintained periodically and certified welders to make repairs to the lining with expensive epoxy coating.



1/3 the weight of steel

Fibreglass vessels weigh only 1/3 the weight of steel vessels while maintaining the same level of strength. Their weight makes them easier to ship to the job site, quicker to install, and reduces structural requirements.

Micron fibreglass filters

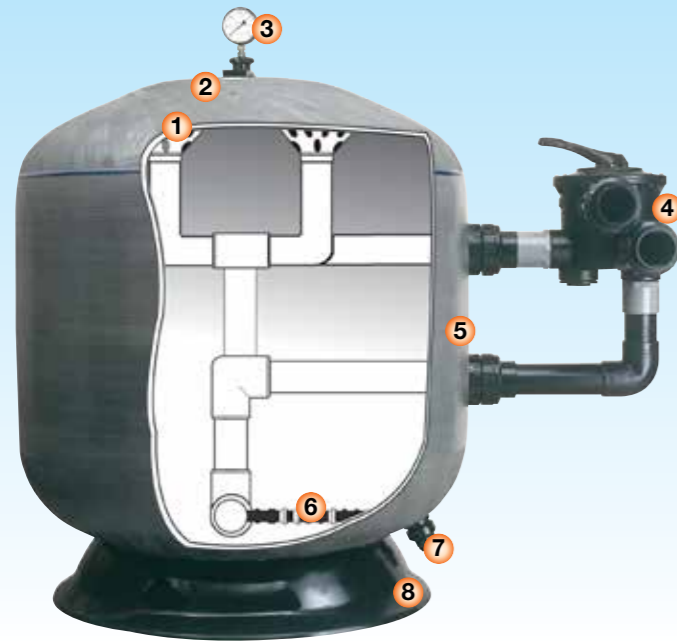

Micron Side Mount Filters

- 1 Inflow diffuser for even distribution of water flow across the filter bed.
- 2 Elliptical positive sealing manways.
- 3 Pressure gauge.
- 4 Six position Multiport valve with sight glass and quick connect half unions.

- Filtration area 0.87m² to 10.0m², 9 to 107 Ft²
- Pressure rated up to 1,000 kPa (150 psi)
- 1 ½", 2", and 3" Water drain w/screen
- Up to 4" Media drain.



Micron Top Mount Filters
* Optional manual drain

- 5 UV and corrosion resistant fibreglass wound tank.
- 6 Hydraulically balanced laterals to maximise water flow and filtration.
- 7 Manual drain*.
- 8 Large filter base for stable floor mounting.

- Maximum working temperature of 50°C (122°F)
- S H. 40 / 80 / equivalent PVC fittings, Polypropylene laterals
- Option of inlet/outlet port connection: quick union up to 4" or flanged port up to 10".

Optional manholes and sight glasses

Waterco's advanced manufacturing capabilities have enabled it to incorporate sight glasses and large manholes into its high-pressure fibreglass filters.



Lateral / side manhole

Opening size			
	420x320mm		320x200mm
	ø320mm		ø200mm
	ø200mm 6bar		ø200mm
8" round (200mm) 12"x 8" (320x200mm)		12" (320mm) 16"x12" (420x320mm)	



Sight Glass

	150mm		100mm
	80mm		50mm
2" round (50mm) 3" round (80mm)		4" round (100mm) 6" round (150mm)	

Micron fibreglass filter construction



Inner shell is constructed from fibreglass reinforced Isothalic polyester approved by NSF.

Resin is of reasonable heat distortion temperature. Option of Vinyl-ester coating is available upon request for ozone applications up to 2ppm.



Fibreglass layer is constructed from 18-ounce combination of high tensile strength chopped strand mat and woven mat, which provides superior multi-directional strength.



Filament winding

Inner shell is filament wound using a computer controlled four-axis machine. The winding angle for polar winding using non-geodesic calculation was generated by advanced winding software. (circumferential) winding provides circumferential strength to the filter tank. Fibreglass roving of up to 2400tex is impregnated into ortho-phthalic Polyester resin in the winding process.



Proprietary manhole & sight glass construction

Generally, large manholes and sight glasses are harder to incorporate in high pressure filters, because any opening in a filter vessel creates a potential weak point or complicates the manufacturing process. Waterco's proprietary fibreglass manufacturing techniques enable the option of large sight glasses and large manholes for its high pressure filters, capable of withstanding up to a 1,000kPa/150psi pressure rating.



Patented port boring

Inlet/outlet ports are bored using a digital controlled boring process for absolute precision. The patented boring process creates perfectly flat parallel internal and external surfaces, perfect for gaskets sealing the inner and outer wall of the filter tank.

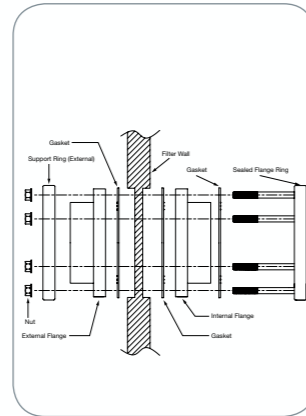

Triple seal with no metal contact

Waterco's unique design does not allow any water contact with its metal flange rings. Three gaskets are incorporated to further guarantee water-tight sealing. Additional lamination reinforcement is provided for large diameter penetrations and man holes.



PVC flange with specialised glass reinforced corrosion-resistant backing ring up to 10" in diameter.



Inlet/outlet ports PVC quick connect union, up to 4" for ease of plumbing and servicing.



Positive sealing manways

Waterco's elliptical positive sealing manways provide reliable access to the filter vessel for visual inspections and cleaning. Each manway is constructed out of fibreglass and comes equipped with dual yokes.

Micron fibreglass filter components



Internal plumbing & laterals

Fibreglass filter vessels are shipped complete - no field installation of internal plumbing is required. All internal plumbing is structurally supported to eliminate potential transit damage.

Waterco laterals and internal plumbing are highly corrosion and chemical resistant. Laterals are constructed from Polypropylene and all internal plumbing constructed from PVC and Polypropylene.



Hydraulically balanced laterals

Micron vertical commercial filters are equipped with "Fish tail" or "Fish-bone" hydraulically balanced laterals, to improve its filtration and backwashing hydraulic efficiency.

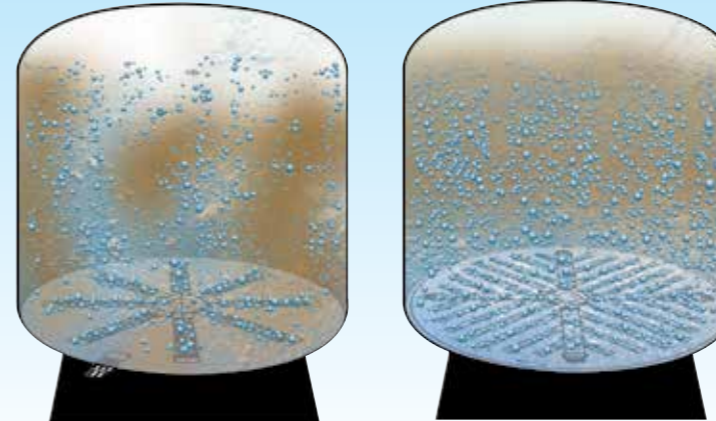

Conventional laterals are not suitable for large-scale commercial filters as "dead legs" exist between the laterals, which compromises water flow through the filter bed. Waterco's unique "fish tail" or "fish bone" lateral configuration eliminates this problem by providing effective coverage of the filter bed and balanced water flow.

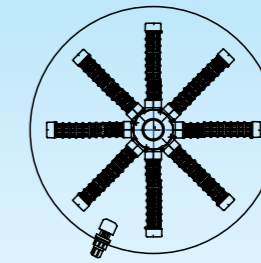

Conventional lateral configuration

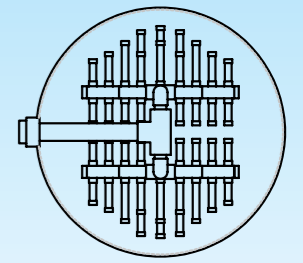

Commercial vertical filters with 3" / 80mm ports

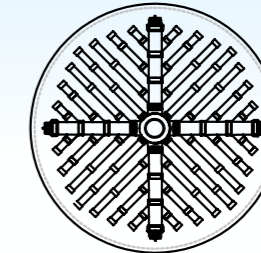

Commercial vertical filters with 2 1/2" / 65mm ports as well as the SD1200 and SD1400 with 3" / 80mm ports

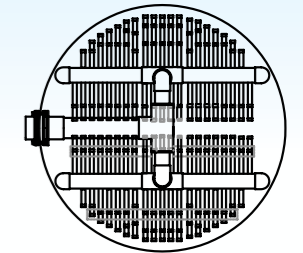

Commercial vertical filters with 4"/100mm, 6"/150mm, 8"/200mm ports

Micron fibreglass filter components



Nozzle plate

Micron SPDD filters are fitted with a plate and nozzle system, which ensures uniform flow for both filtering and backwashing. This ensures maximum performance through the media bed.

The nozzle plate system also allows the introduction of pressurised air directly into the bottom of the filter media. Uniform introduction of air and water through the nozzle plate provides vigorous agitation and filter media expansion required for an effective air/water backwash leading to reduced backwashing times and reduced volumes of water. This saves up to 25% of backwash water.



Patented nozzle plate filter

Waterco has developed a new method of fabricating a nozzle plate filter, which practically eliminates failure rates experienced in most other nozzle plate filters. This process has been granted a patent in Australia, with patent pending in other parts of the world.

Nozzle plate filters historically have a higher rate of failure, whether they are made of fibreglass, stainless steel or mild steel coated with anti-corrosive material. Nozzle plates are traditionally attached to the wall of the filter, separating the unfiltered water and filtered water of the tank. During filtration mode as well as backwashing mode, the plate has cyclic movement vertically flexing upwards and downwards, whereas the wall of the filter has cyclic movements horizontally flexing inwards and outwards.

That critical joint is the Achilles heel of most nozzle plate filters. Over time, with two different axes of expansion and contraction, the joint weakens and breaks.

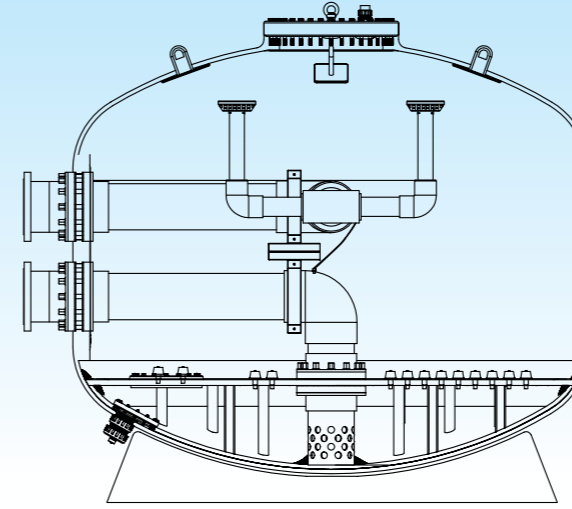

Flexible joint

Waterco's unique construction method eliminates this problem, by creating a separate chamber within the filter. Additionally, the nozzle plate is attached to the wall of the filter with a flexible joint, instead of traditionally attaching a rigid joint. This removes the stress typically found in traditional nozzle plate filters, further enhancing the durability of these filters.

Waterco's Micron nozzle plate filters have been installed in a number of commercial projects including the Shoaiba power and desalination plant in Saudi Arabia. An oil-fired combined cycle gas turbine plant, Shoaiba is the world's third largest integrated water and power plant.

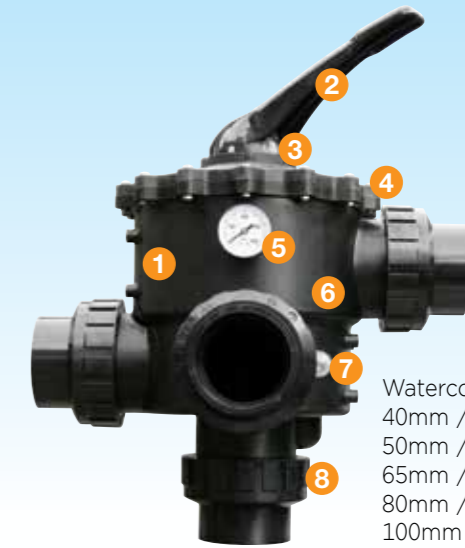

Waterco MPV's are available in 40mm / 50mm (EU) / 1 1/2", 50mm / 63mm (EU) / 2", 65mm / 75mm (EU) / 2 1/2", 80mm / 90mm (EU) / 3" and 100mm / 110mm (EU) / 4"

Waterco Multiport valves

Constructed from heavy duty ABS and GFPP, Waterco Multiport valves are designed for maximum performance and working pressures. Waterco's entire range of Multiport valves are engineered to withstand a working pressure of up to 400 kPa (58 psi) with a test pressure of 600 kPa (87 psi).

- 1 Glass filled thermoplastic.
- 2 Durable lever action handle.
- 3 6-way multiple valve positions.
- 4 High grade stainless steel components.
- 5 Pressure gauge.
- 6 Wear resistant rotor.
- 7 Clear backwash sight glass.
- 8 Metric or imperial quick connect unions.

Micron horizontal filters

The Micron horizontal filter is a space-saving high performer; its compact horizontal design allows installation with minimum waste of space. The shape of the Micron horizontal filter is

both attractive and functional. The spherical ends are designed to give uniform flow from both inlet and outlet collection assemblies. Micron horizontal filters are available with a 500mm (M) filter media bed and a 1200mm (MD) filter media bed.

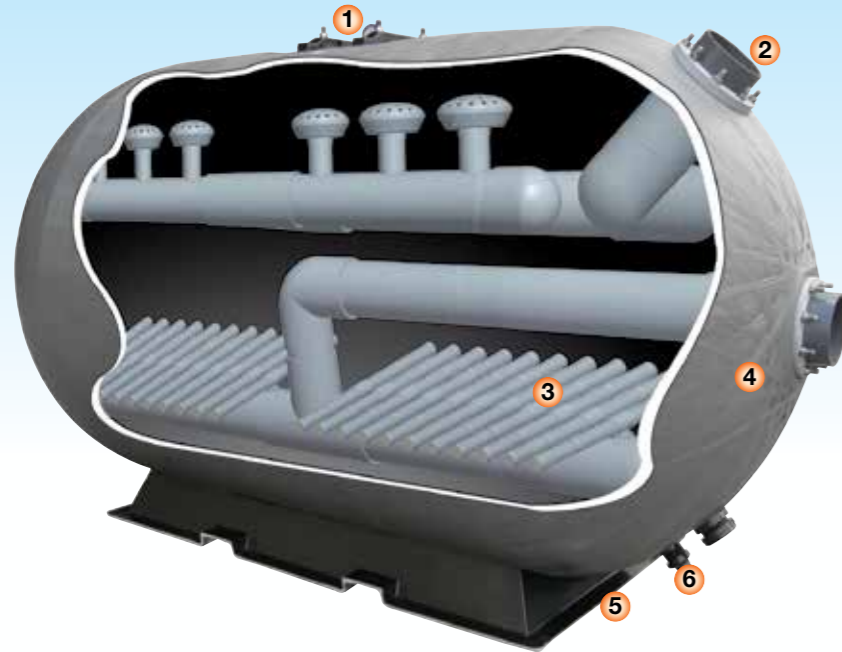

- 1 Elliptical positive sealing manways.
- 2 Flanged port of up to 10".
- 3 Hydraulically balanced distribution and lateral system.
- 4 Fibreglass wound tank, UV and corrosion resistant.
- 5 Large stable filter base for stable floor mounting.
- 6 Manual drain.

Hydraulically balanced lateral configuration

Conventional lateral systems result in uneven fluidisation of the filter media bed. The beginning of the lateral system experiences a strong flow of water, which gradually decreases along the length of the lateral piping. Backwash flow also decreases towards the end of each lateral, resulting in non-uniform lifting of the filter media bed.

Waterco's new lateral configuration provides a more natural flow of water through the filter, ensuring optimum water filtration and balanced fluidisation of the filter bed during backwashing. Its individual laterals are shortened while maintaining filter media bed coverage to reduce the friction head loss of each lateral and further improve the filter's hydraulic efficiency. This reduces backwash run times, saves valuable water, and produces flatter, more uniform filter media bed after backwashing.

10-year Warranty

Filter Tank	10 years (5 year full + 5 years pro rata)
Multiport Valve & other components	1 year

Waterco Commercial Pumps, Filters & Accessories



Hydron split-tank filters can be delivered in two parts and assembled on site in the plant room. The two halves seal perfectly, using double o'ring and held together by a flange using bolt and nuts.



A revolution in pool filtration, MultiCyclone 70XL is a brilliant pre-filtration device that works on the basis of centrifugal water filtration and is designed with no moving parts and no filter media to clean or replace.



Purposed built for aquatic facilities, water parks and large commercial swimming pools. Hydrostar Plus pumps are high performance corrosion resistant thermoplastic pumps.



Constructed from composite materials, the Hydro 5000 commercial strainer is a totally non-corrosive strainer, designed for aquatic facilities, water parks and large commercial swimming pools.

Waterco Limited

Established since 1981, Waterco is an Australian publicly listed company involved in the manufacture and distribution of swimming pool and spa equipment and chemicals, domestic water filters, softeners and purifiers, and commercial and industrial water treatment equipment.

Waterco's research and development team has created an innovative range of award-winning products. The company's advanced fibreglass winding and pioneering plastic moulding techniques have delivered premium quality products to over 40 countries via its branches operating in Australia, New Zealand, Malaysia, China, the United Kingdom, United States of America, Canada, Indonesia and Singapore.

OFFICES - AUSTRALIA

NSW - Sydney (Head Office)

Tel: +61 2 9898 8600

QLD - Brisbane

Tel: +61 7 3299 9900

VIC/TAS - Melbourne

Tel: +61 3 9764 1211

WA - Perth

Tel: +61 8 9273 1900

SA/NT - Adelaide

Tel: +61 8 8244 6000

ACT Distribution

Tel: +61 2 6280 6476

OFFICES - OVERSEAS

Waterco (Europe) Limited

Sittingbourne, Kent, UK
Tel: +44 (0) 1795 521 733

Waterco France

Saint Priest, France
Tel: +33 4 72 79 33 30

Waterco (USA) Inc

Augusta, Georgia, USA
Tel: +1 706 793 7291

Waterco Canada

Longueuil, Qc, Canada
Tel: +1 450 748 1421

Waterco (NZ) Limited

Auckland, New Zealand
Tel: +64 9 525 7570

Waterco (C) Limited

Guangzhou, China
Tel: +86 20 3222 2180

PT Waterco Indonesia

Jakarta, Indonesia
Tel: +62 21 4585 1481

Waterco Singapore Intl Pte Ltd

Nehsons Building, Singapore
Tel: +65 6344 2378

Waterco (Far East) Sdn Bhd

Selangor, Malaysia
Tel: +60 3 6145 6000

Distributed by:

WATERCO
water, the liquid of life



In the interest of providing better quality and value we are constantly improving and updating our products. Consequently, pictures and information on our brochures may sometimes vary slightly from models available.